

UVA - BUTLER™ - 4 Series

Intermittent Motion Packaging Machine



Packaging Solutions and Technology

UVA - BUTLER™ - 4 series

Multi Brand Former Adapter

- ▶ Accepts former sets from all brands (Patent pending)
- ▶ Most economic packaging machine
- ▶ Accepts low cost Flexi Former



Split Frame Design

- ▶ Divisible into a packaging sections and unwind section
- ▶ Packaging section separate obtainable
- ▶ Packaging section easy connectable to an UVA-Autosplicer or an UVA-Cornersealer

Green Technology

- ▶ Low CO² footprint
- ▶ Runs at 4 bar airpressure
- ▶ Low energy sealing jaws
- ▶ Low weight

Compact Design

- ▶ Small footprint and height
- ▶ Allows easy replacement of any packaging machine

World Service Program

- ▶ 24/7 technical support
- ▶ Service contract including maintenance



UVA - FLEXIFORMER

Contact Details

Head Office • PMB-UVA International B.V.

T +31 (0)40 282 5000 • F +31 (0)40 282 5001 • Meerenakkerweg 32 • 5652 AV Eindhoven • The Netherlands • sales@uva-packaging.com • www.uva-packaging.com

Northern American Division • UVA Packaging

T +1-804 275 8067 • F +1-804 271 3096 • 8111 Virginia Pine Ct. • Richmond, Virginia 23237 • United States of America • info@pmb-uvainc.com • www.pmb-uvainc.com

Detailed Machine Specifications



UVA - BUTLER[™] - 4 series

Machine Design

- ▶ Hygienic design: "easy to clean"
- ▶ Easy height configuration due to unique "bridge concept"
- ▶ Sanitary easy clean

Controls

- ▶ Machine control through A-brand PLC
- ▶ 10" colour touch screen for production information and fault display
- ▶ 100 production program memory for quick changeovers
- ▶ Slip compensation for exact bag length
- ▶ Servo loop controlled machine, reduces wear at high performance

Efficiency Management

- ▶ Low energy sealing jaws
- ▶ Production counter with reset button at control panel
- ▶ Easy and quick change of sealing jaws and sealing system
- ▶ Program selectable cross jaw opening for maximum output with different bag sizes
- ▶ Extra inputs for synchronisation

Ease of Use

- ▶ Temperature controllers with precise, separate control for front, rear and long seal jaws

After Sales Service

- ▶ Low cost on maintenance, uptime guaranteed
- ▶ Global and service network contract possibilities

Easy Upgrades

- ▶ Efficiency upgrades

UVA - BUTLER[™] - 4 + UVA - AUTOSPLICER[™]

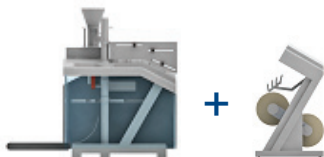

- ▶ Flexibility upgrades

UVA - BUTLER[™] - 4 + UVA - CORNERSEALER[™]

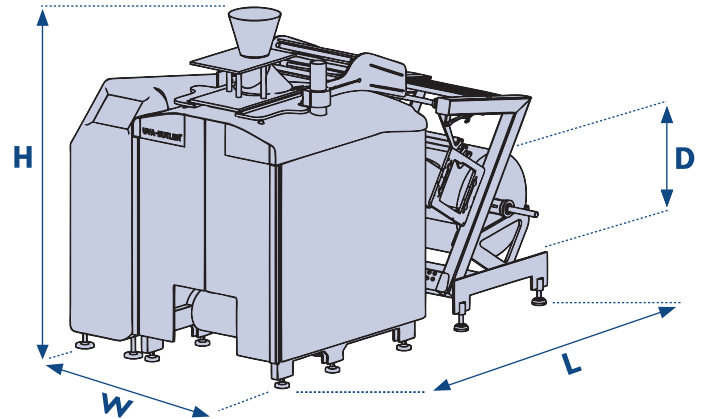
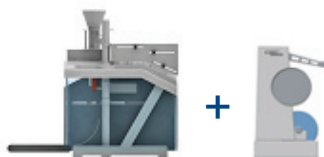

Machine Specification

	Butler-4-220	Butler-4-320
Technology	Intermittent Motion	
Bag width	50-220 mm	120-320 mm
Bag width, block bottom	40-160 mm	80-290 mm
Front to back, block bottom	45-110 mm	45-120 mm
Bag length	400 mm	
Power consumption	1,2 kVA	
Air requirements	4 bar	
Maximum film roll width	470 mm	680 mm
Maximum film reel diameter (D)	550 mm	
Core diameter	76 mm	
Maximum machine output	120 bags/min.	
Machine weight approximately	650 kg	
Dimensions (stand.) HxWxL in mm	1650 x 1350 x 2100	

Bag Styles

	max. Speed
Pillow	✓ 120 bpm
Block Bottom	✓ 70 bpm
Gusseted	✓ 70 bpm

Ease of Use

Easy opening	✓
Euro log	✓

Note: All specification on this leaflet can be subject to change without prior notification from UVA Packaging BV.

UVA Packaging is a VDL company